

SI-3000P Series

3-Terminal, Dropper Type

■Features

- TO-3P package 3-terminal regulator
- Output current: 2.0A
- Wide range of DC input voltage
- Built-in foldback overcurrent protection circuit

■Applications

- For stabilization of the secondary stage of switching power supplies
- Electronic equipment

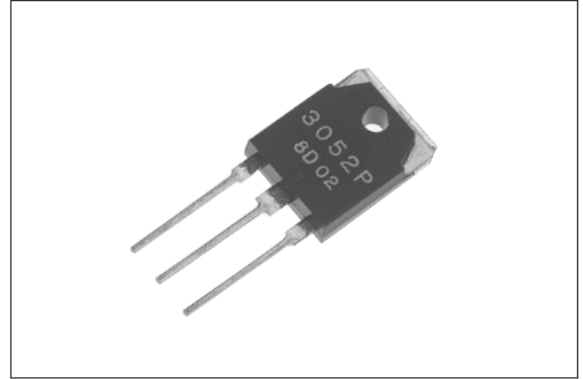

■Absolute Maximum Ratings

(Ta=25°C)

Parameter	Symbol	Ratings	Unit
DC Input Voltage	V _{IN}	45	V
DC Output Current	I _O	2.0	A
Power Dissipation	P _{D1}	50(T _C =25°C)	W
	P _{D2}	2.0(Without heatsink, stand-alone operation)	W
Junction Temperature	T _J	-30 to +125	°C
Ambient Operating Temperature	T _{OP}	-20 to +80	°C
Storage Temperature	T _{STG}	-30 to +125	°C
Thermal Resistance (junction to case)	R _{th(j-c)}	2.0	°C/W

■Electrical Characteristics

(Ta=25°C)

Parameter	Symbol	Ratings												unit
		SI-3052P			SI-3122P			SI-3152P			SI-3242P			
		min.	typ.	max.	min.	typ.	max.	min.	typ.	max.	min.	typ.	max.	
Input Voltage	V _{IN}	8		30	15		35	18		40	27		40	V
Output Voltage	V _O	4.9	5.0	5.1	11.8	12.0	12.2	14.8	15.0	15.2	23.8	24.0	24.2	V
	Condi ions	V _{IN} =10V, I _O =0.5A			V _{IN} =19V, I _O =0.5A			V _{IN} =23V, I _O =0.5A			V _{IN} =33V, I _O =0.5A			
Dropout Voltage	V _{DF}			3			3			3			3	V
	Condi ions	I _O =2.0A												
Line Regulation	ΔV _{O LINE}		2	10		10	30		10	30		25	50	mV
	Condi ions	V _{IN} =8.5 to 11.5V, I _O =0.5A			V _{IN} =16 to 22V, I _O =0.5A			V _{IN} =19.5 to 26.5V, I _O =0.5A			V _{IN} =28 to 38V, I _O =0.5A			
Load Regulation	ΔV _{O LOAD}		40	100		80	200		80	200		120	300	mV
	Condi ions	V _{IN} =10V, I _O =0 to 2.0A			V _{IN} =19V, I _O =0 to 2.0A			V _{IN} =23V, I _O =0 to 2.0A			V _{IN} =33V, I _O =0 to 2.0A			
Temperature Coefficient of Output Voltage	ΔV _O /ΔT _a		±0.5			±1.5			±1.5			±2.5		mV/°C
Ripple Rejection	R _{REJ}		60			60			60			60		dB
	Condi ions	f=100 to 120Hz												
Overcurrent Protection Starting Current	I _{S1}	2.4			2.4			2.4			2.4			A
	Condi ions	V _{IN} =10V			V _{IN} =19V			V _{IN} =23V			V _{IN} =33V			
Limited Current at Overcurrent Protection Operation	I _{S2}			0.6			0.6			0.6			0.6	A
	Condi ions	V _{IN} =10V			V _{IN} =19V			V _{IN} =23V			V _{IN} =33V			

■Outline Drawing

(unit:mm)

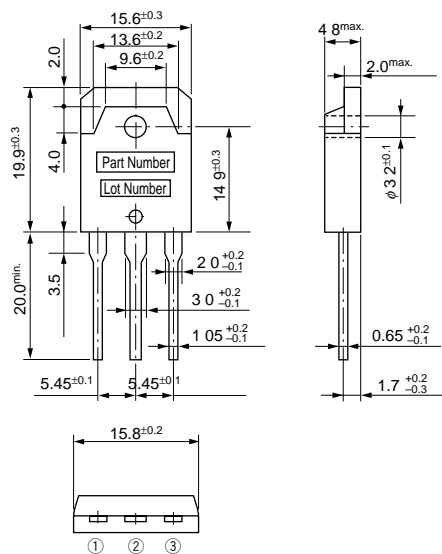

Plastic Mold Package Type (TO-3P)

Flammability: UL94V-0

Weight: Approx. 6g

Terminal Connections

- ① Output
- ② Input (backside of case)
- ③ Ground

■Block Diagram

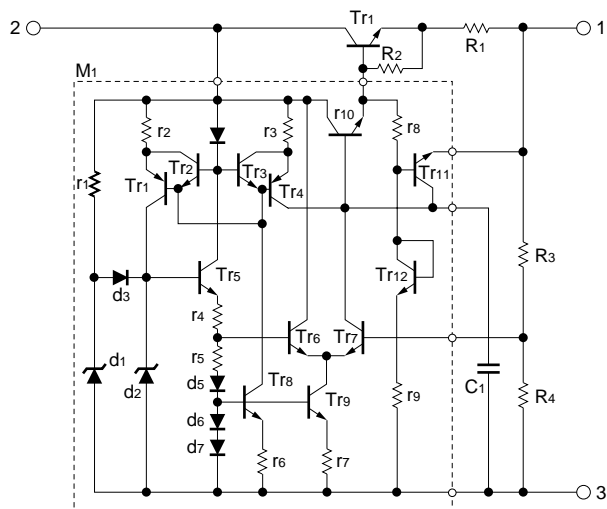

■Standard External Circuit

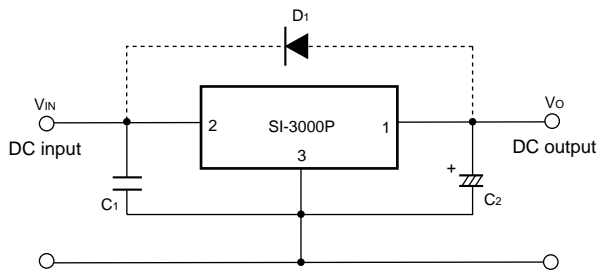

- C1: Oscillation prevention capacitor (approx. 0.33 μ F)
Connection to terminal No.2 must be made as short as possible.
- C2: Output capacitor (47 to 100 μ F)
Connection to terminal No.1 must be made as short as possible.
- D1: Protection diode (RM1Z)
Required for protection against reverse biasing of input and output.

Note 1: Connect a 47 μ F to 100 μ F capacitor to both sides of the load if the wiring between the output terminal and the load is long.

Note 2: An isolation type diode is provided from input to ground and also from output to ground. These may be destroyed if the device is reverse biased. In this case, use a diode with low V_F to protect them.

Note 3: The output voltage may not be adjusted by raising the ground voltage (using a diode or resistor).

■ T_a - P_D Characteristics

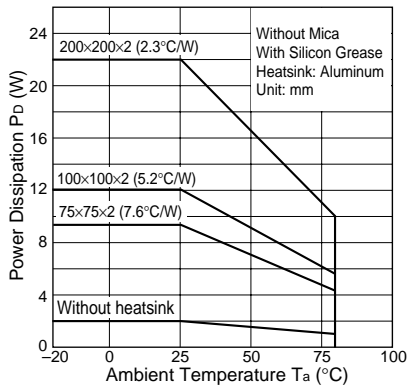

■Typical Characteristics

($T_a=25^\circ\text{C}$)

I_o vs. V_{DIF} Characteristics

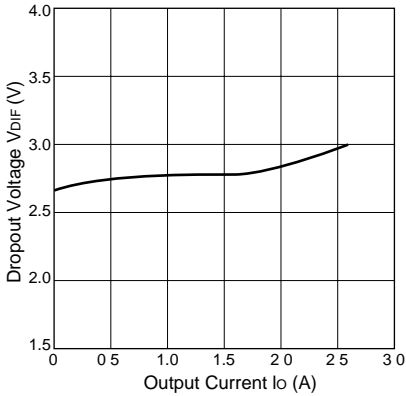

Temperature Coefficient of Output Voltage(SI-3052P)

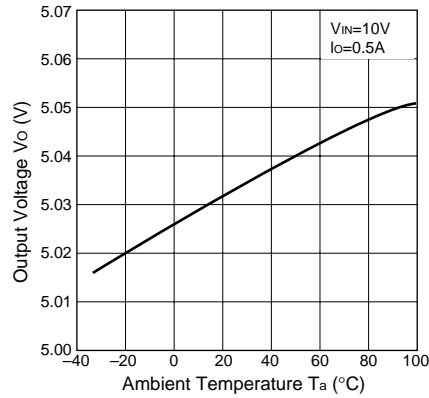

Circuit Current(SI-3052P)

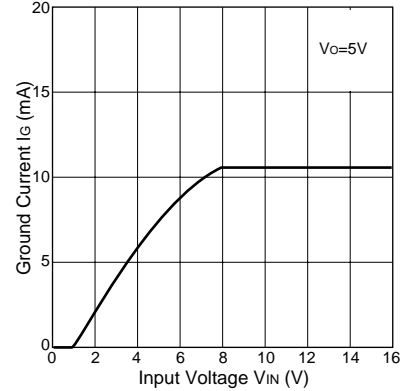

Rise Characteristics(SI-3052P)

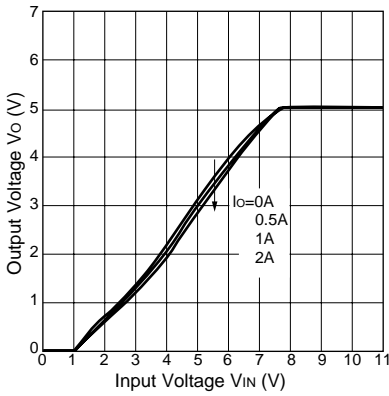

Rise Characteristics(SI-3122P)

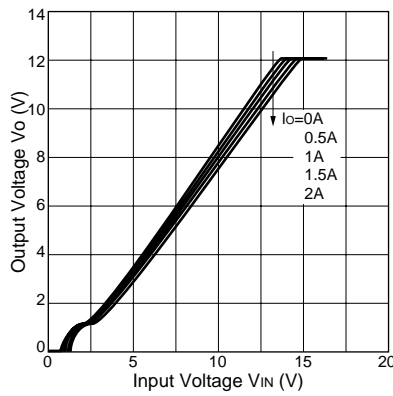

Rise Characteristics(SI-3242P)

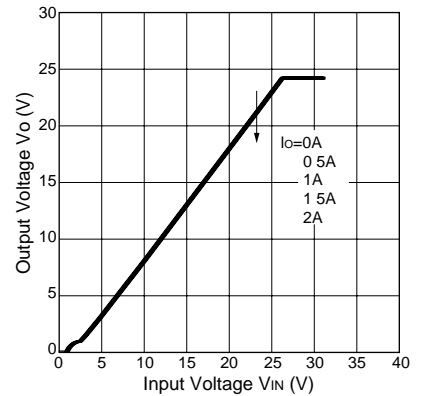

Overcurrent Protection Characteristics(SI-3052P)

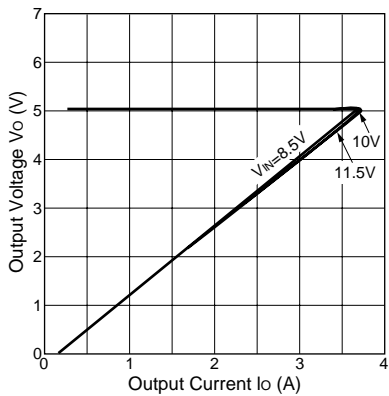

Overcurrent Protection Characteristics(SI-3122P)

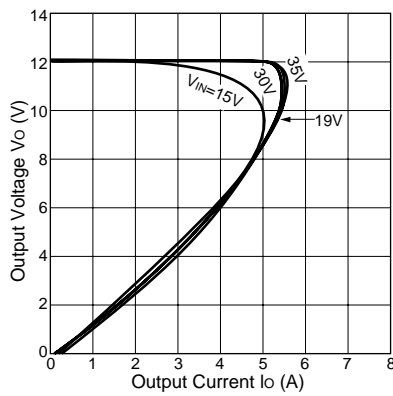

Overcurrent Protection Characteristics(SI-3242P)

